

ANDHRA PRADESH PUBLIC SERVICE COMMISSION :: VIJAYAWADA

ASSISTANT ELECTRICAL INSPECTORS IN A.P. ELECTRICAL INSPECTORATE SERVICE

PAPER-2 ELECTRICAL ENGINEERING

INITIAL KEY

1. In the circuit shown in Fig. 1, the maximum power transferred to the resistor R

3.025 W

2. The impedance looking into nodes 1 and 2 in given circuit is

(a) 50 Ω

3. In the given figure, the Thevenin's equivalent (voltage, impedance), as seen at the terminals P-Q, by

(2 V, 5 Ω)

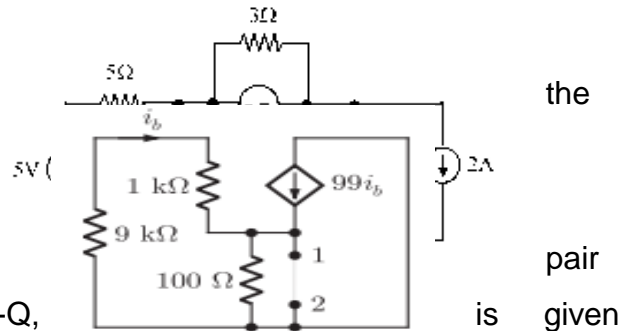

4. If, at $t = 0^+$, the voltage across the coil is 120 V, the of resistance R is

0 Ω

5. Figure shows the waveform of the current passing through an inductor of resistance and inductance 2 H. The energy absorbed inductor in the first four seconds is

132 J

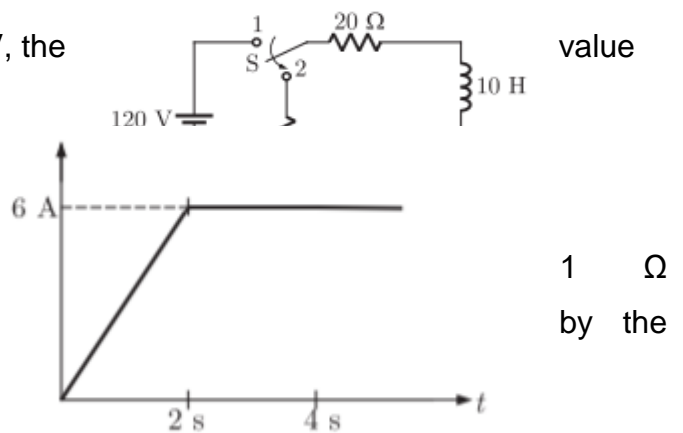

6. A 11 V pulse of 10 μs duration is applied to the circuit shown in Figure, assuming that the capacitor is completely discharged prior to applying the pulse, the peak value of the capacitor voltage is

6.32V

7. A system with transfer function $G(s) = (S^2 + 9) (S + 2) / (S + 1) (S + 3) (S+4)$ is excited by $\sin \omega t$. The steady-state output of the system is zero at

$\omega = 3 \text{ rad/s}$

8. The value of Z in Fig., which is most appropriate to cause parallel resonance at 500 Hz, is

0.05 μF

9. The impedance seen by the source in the circuit in Fig. is by

(4.54 - j1.69) Ω

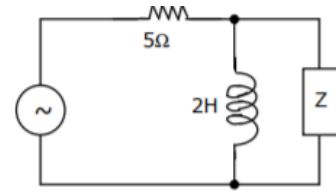

given

10. A two-port device is defined by the following pair of equations:

$$i_1 = 2V_1 + V_2 ; i_2 = V_1 + V_2. \text{ Its impedance parameters } \begin{bmatrix} Z_{11} & Z_{12} \\ Z_{21} & Z_{22} \end{bmatrix} \text{ are given by}$$

$$\begin{bmatrix} 1 & -1 \\ -1 & 2 \end{bmatrix}$$

11. The h-parameters for a two-port network are defined by $\begin{bmatrix} E_1 \\ I_2 \end{bmatrix} = \begin{bmatrix} h_{11} & h_{12} \\ h_{21} & h_{22} \end{bmatrix} \begin{bmatrix} I_1 \\ E_2 \end{bmatrix}$.

For the two-port network shown in Fig., the value of h_{12} is given by

0.25

12. Two networks are connected in cascade as shown in Figure. With the usual notations the equivalent A, B, C and D constants are obtained. Given that $C = 0.025 \angle 45^\circ$, the value of Z_2 is:

$40 \angle -45^\circ \Omega$

13. Find the values of I_1 and I_2 if the transmission parameters for the two-port network in Fig. are

$$\begin{bmatrix} 5 & 10 \Omega \\ 0.4 \text{ S} & 1 \end{bmatrix}$$

1 A, -0.2 A

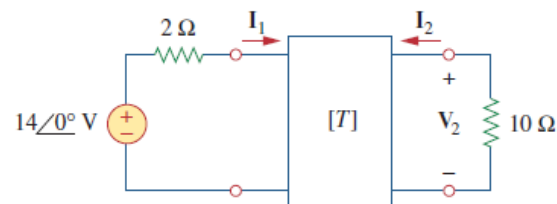

5.6

14. A three-phase motor can be regarded as a balanced Y-load. A three phase motor draws kW when the line voltage is 220 V and the line current is 18.2 A. The power factor of the motor is _____?

0.8075

15. The line-to-line input voltage to the 3 phase, 50 Hz, ac circuit shown in Fig. is 100 V rms. Assuming that the phase sequence is RYB, the wattmeters would read _____?

$W_1 = 0 \text{ W}$ and $W_2 = 1000 \text{ W}$

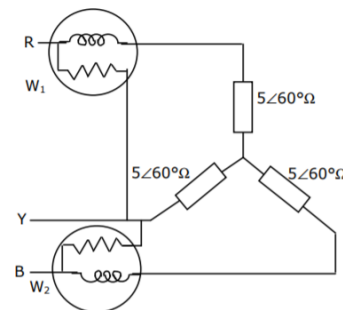

16. A parallel plate capacitor has an electrode area of 100 mm^2 , with spacing of 0.1 mm between the electrodes. The dielectric between the plates is air with a permittivity of $8.85 \times 10^{-12} \text{ F/m}$. The voltage on the capacitor is 100 V . The stored energy in the capacitor is

44.3 nJ

17. Given a vector field \vec{F} , the divergence theorem states that

$$\iiint_V \vec{F} \cdot d\vec{s} = \int_V \nabla \cdot \vec{F} dv$$

18. Match the following

List I

- A. Stoke's theorem
- B. Gauss's theorem
- C. Divergence theorem
- D. Cauchy's integral theorem

List II

- 1. $\iint \vec{D} \cdot d\vec{s} = Q$
- 2. $\oint f(z) dZ = 0$
- 3. $\iiint (\nabla \cdot \vec{A}) dv = \iint A \cdot d\vec{s}$
- 4. $\iint (\nabla \times \vec{A}) d\vec{s} = \oint \vec{A} \cdot d\vec{l}$

Codes:

4 1 3 2

19. Consider the following statements with reference to the equation $\nabla \cdot \vec{J} = -\frac{\partial \rho}{\partial t}$

- i. This is a point form of the continuity equation
- ii. Divergence of current density is equal to the decrease of charge per unit volume per unit time at every point
- iii. This is maxwell's divergence equation
- iv. This represents the conservation of charge

Select the correct answer.

i, ii and iv are true

20. The line integral of the vector potential \mathbf{A} around the boundary of a surface \mathbf{S} represents

Flux through the surface S

21. One of these equations given below is not Maxwell's equation for a static electromagnetic field in a linear homogeneous medium. The correct answer is

$$\nabla^2 A = \mu_0 J$$

22. What is the major factor for determining whether a medium is free space, lossless di-electric, lossy dielectric, or good conductor?

Loss tangent

23. A (0-25) A ammeter has a guaranteed accuracy of 1 percent of full scale reading. The current measured by this instrument is 10 A. Determine the limiting error in percentage.

2.5%

24. The measured value of a capacitor is 205.3 μF , whereas its true value is 201.4 μF . Determine the relative error.

1.94%

25. A 53 Hz reed type frequency meter is polarized with D.C. The new range of frequency meter is

106 Hz

26. The following readings are obtained for one month of 30 days, KWh meter = 360000, Demand indicator = 15000 **kW**. Find out the average monthly load factor

0.0333

27. A moving coil has a resistance of 0.6 Ω and a full scale deflection current of 0.1 A. To convert it into an ammeter of (0-15) A range, the resistance of shunt should be

0.004 Ω

28. A spring controlled moving iron voltmeter draws a current of 1mA for full scale value of 100 V. If it draws a current of 0.5 mA, the meter reading is

25 V

29. Two voltmeters of (0-300) V range are connected in parallel to a A.C. circuit. One voltmeter is moving iron type reads 200V. If the other is PMMC instrument, its reading will be

Zero

30. The items in Group I represent the various types of measurements to be made with a reasonable accuracy using a suitable bridge. The items in Group II represent the various bridges available for this purpose. Select the correct choice of the item in Group II for the corresponding item in Group I from the following

- | | | | |
|---|--|---|----------------------|
| P | Resistance in the milli-Ohm range | 1 | Wheatstone Bridge |
| Q | Low values of Capacitance | 2 | Kelvin Double Bridge |
| R | Comparison of resistances which are nearly equal | 3 | Schering Bridge |
| S | Inductance of a coil with a large time constant | 4 | Wien's Bridge |
| | | 5 | Hay's Bridge |
| | | 6 | Carey-Foster Bridge |

P – 2, Q – 3, R – 6, S – 5

31. The bridge circuit shown in the figure below is used for the measurement of an unknown element Z_x . The bridge circuit is best suited when Z_x is a

low Q inductor

32. A bridge circuit is shown in the figure below. Which one of the sequence given below is most suitable for balancing the bridge?

First adjust R_2 , and then adjust R_4

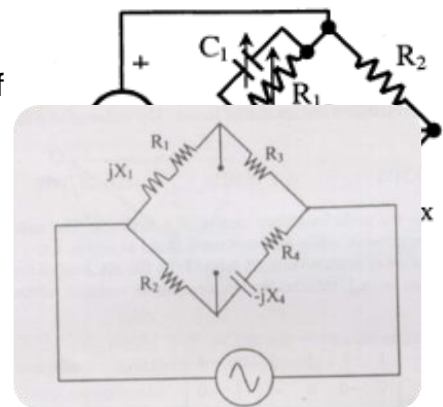

33. Group II represents the figures obtained on a CRO screen when the voltage signals $V_x = V_{xm} \sin \omega t$ and $V_y = V_{ym} \sin(\omega t + \Phi)$ are given to its X and Y plates respectively and Φ is changed. Choose the correct value of Φ from Group I to match with the corresponding figure of Group II

Group I

Group II

- P $\Phi=0$
- Q $\Phi=\pi/2$
- R $\pi < \Phi < 3\pi/2$
- S $\Phi=3\pi/2$

P – 1, Q – 5, R – 6, S – 4

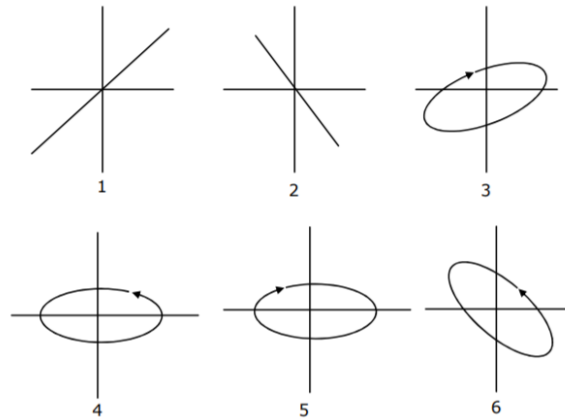

34. A CRT has an anode voltage of 2000 V and a parallel deflection plates 2 cm long and 5 mm apart. The screen is 30 cm from the center of the plates. Find the input voltage required to deflect the beam through 3 cm. The input voltage is applied to the deflection plates through amplifiers having an overall gain of 100

1 V

35. A CRO screen has ten divisions of horizontal scale. If a voltage signal $5 \sin (314 t + 45^\circ)$ is examined with a line base setting of 5 msec/div, the number of cycles of signal displayed on the screen will be

2.5 cycles

36. Feedback control systems are

Less sensitive to forward path parameter changes than to feedback path parameter changes

37. The signal flow graph of a system is shown below. $U(s)$ is the input and $C(s)$ is the output.

Assuming, $h_1 = b_1$ and $h_0 = b_0 - b_1 a_1$, the input-output transfer function, $G(s) = \frac{C(s)}{U(s)}$ of the

system is given by

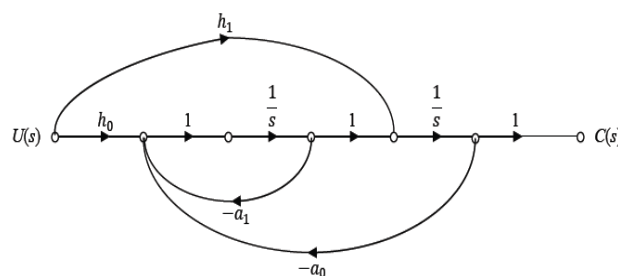

$$G(s) = \frac{b_1s + b_0}{s^2 + a_1s + a_0}$$

38. For what value of K, the time constant of the given system is equal to 0.2 seconds

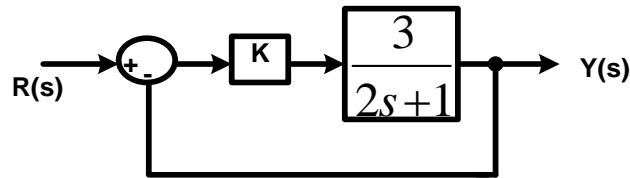

$$K = 3$$

39. For the system $\frac{2}{s+1}$, the approximate time taken for a step response to reach 98% of its final value is

4 s

40. For a type 1, second order control system, when there is an increase of 25% in its natural frequency, the steady state error to unit ramp input is

Decreased by 20%

41. If the loop gain K of a negative feedback system having a loop transfer function $\frac{K(s+3)}{(s+8)^2}$ is to be adjusted to induce a sustained oscillation, then

The frequency of this oscillation must be 4 rad/s

42. The characteristic equation of a closed-loop system is $s(s+1)(s+3) + k(s+2) = 0, k > 0$. Which of the following statements is true?

Two of its roots tend to infinity along the asymptotes $Re[s] = -1$

43. A unity feedback system has forward path transfer function $G(s) = \frac{K}{s(s+4)(s+5)}$ the breakaway point lies between

0 and -4

44. The magnitude Bode plot of a network is shown in the figure

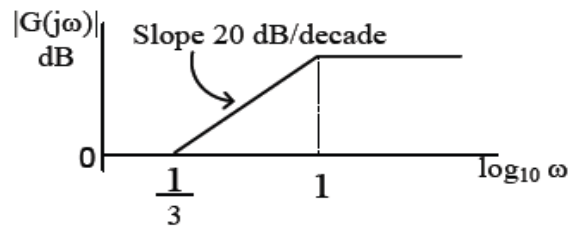

The maximum phase angle ϕ_m and the corresponding gain G_m respectively, are

+30° and 4.77dB

45. Which of the following transfer function is a non-minimum phase transfer function

$$\frac{(s-1)}{(s+2)(s+3)}$$

46. The open loop transfer function of a unity feedback system is $G(s) = \frac{K}{(s-1)(s^2+4s+7)}$. The

Nyquist contour is in s-plane. For $K > 0$ the Nyquist plot is shown in $G(s) H(s)$ plane. The system is stable for

$7 < K < 16$

47. Maximum phase-lead of the compensator $D(s) = \frac{0.5s+1}{0.05s+1}$ is

None of the above

48. A Synchro Transmitter is used with control transformer for:

Error detection

49. Consider the system $A = \begin{bmatrix} 0 & -2 \\ 1 & -3 \end{bmatrix}$; $B = \begin{bmatrix} 1 \\ 1 \end{bmatrix}$; $C = [0 \ 1]$. The transfer function of the system has pole-zero cancellation. The system is

Observable but uncontrollable

50. A state variable formulation of a system is given by the equations, $\begin{bmatrix} \dot{x}_1 \\ \dot{x}_2 \end{bmatrix} = \begin{bmatrix} -1 & 0 \\ 0 & -3 \end{bmatrix} \begin{bmatrix} x_1 \\ x_2 \end{bmatrix} + \begin{bmatrix} 1 \\ 1 \end{bmatrix} u$

and $y = [1 \ 0] \begin{bmatrix} x_1 \\ x_2 \end{bmatrix}$ then the transfer function of the system is

$$\frac{1}{(s+1)}$$

51. Assume that D_1 and D_2 in Fig. are ideal diodes. The value of current I is

0 mA

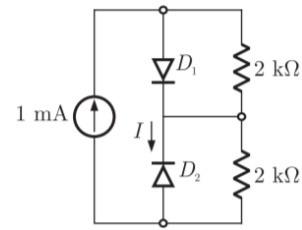

52. Find the average value of the full-wave rectified voltage waveform shown in Fig. 2

9.55 V

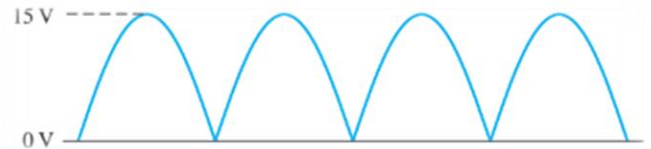

53. For a certain 12V zener diode, a 10mA change in zener current produces a 0.1V change in zener voltage. The zener impedance for this current range is

10 Ω

54. A varactor diode exhibits

a variable capacitance that depends on reverse voltage

55. A transistor has a current gain of 0.99 in common base mode. Its current gain in common emitter mode is

99

56. A certain transistor is to be operated with $V_{CE} = 6$ V. If its maximum power rating is 250 mW, what is the most collector current that it can handle?

41.7 mA

57. The transistor shown in Fig. has the following maximum ratings: $P_{D(max)} = 800$ mW, $V_{CE(max)} = 15$ V, and $I_{C(max)} = 100$ mA. What is the value of voltage drop across the resistor R_C ?

19.5 V

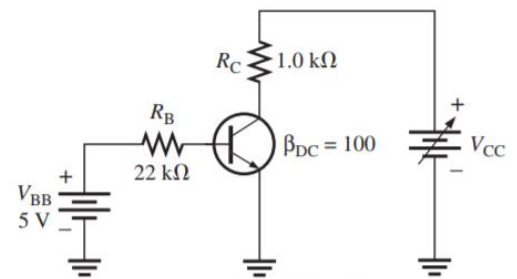

58. For the voltage-divider-bias circuit shown in Fig., the value of voltage at emitter terminal V_E is?

2.89 V

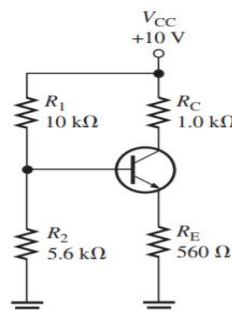

59. Each stage of a four-stage amplifier overall voltage gain is

50,625

has a voltage gain of 15. The

60. The JFET has typically $I_{DSS} = 9 \text{ mA}$ and $V_{GS(off)} = -8 \text{ V}$ (maximum). The value of drain current for $V_{GS} = 0 \text{ V}$ is

(a) 9 mA

61. A differential amplifier has a differential gain of 20,000 and CMRR of 80 dB. The common mode gain is given by

2

62. A certain op-amp has bias currents of $50 \mu\text{A}$ and $49.3 \mu\text{A}$. The input off-set current is

700 nA

63. A certain non-inverting amplifier has an input resistance R_i of $1.0 \text{ k}\Omega$ and R_f of $100 \text{ k}\Omega$. The closed-loop gain is

101

64. In a monostable multivibrator using 555 timer, the time delay is 100 ms , timing resistor is $100 \text{ k}\Omega$. The value of timing capacitor is

0.9 μF

65. An amplifier has a voltage gain of 120. To reduce distortion, 10 % negative feedback is employed. The gain of the amplifier with feedback is

9.23

66. For the circuit shown in Fig. the Boolean expression for the output Y in terms of inputs P, Q, R and S is

$$Y = P + Q + R + S$$

67. The output of a logic gate is '1' when all the inputs are at logic '0'. The gate is either

A NOR or an EX-NOR gate

68. The initial state of MOD 16 counter is 0110. After 37 clock pulses, the state of the counter will be

1011

69. The resolution of a 12-bit A/D converter having a full-scale analogue input voltage of 5 V is?

1.22 mV

70. The highest priority interrupt in 8085 microprocessor system is

TRAP

71. The energy stored in a magnetic field is given by

- i. $\frac{1}{2} Li^2$ ii. $\frac{1}{2} \Phi^2 Rl$ iii. $\frac{1}{2} (mmf)^2 \square Rl$ iv. $\frac{1}{2} \psi \square l$

From these, the correct answer is

i, ii, iv

72. A 36-slot, 4-pole, DC machine has a simplex lap winding with two conductors per slot. The back pitch and front pitch adopted could be respectively

19,17

73. If the flux per pole of a DC generator is doubled but its speed is halved, its generated E.M.F. will be

Remain the same

74. A 220 V DC machine has an armature resistance of 1 Ω . If the full-load current is 20 A, the difference in the induced voltages when the machine is running as a motor and as a generator is

40 V

75. In a DC machine, which of the following statements is true?

Compensating winding is used for neutralizing armature reaction while interpole winding is used for improving commutation and reactance voltage

76. A 220 V shunt motor develops a torque of 60 N-m at an armature current of 10 A. The torque developed when the armature current is 20 A is

120 N-m

77. Consider the following statements:

A DC shunt-motor starter ensures that

- i. Armature current is under limit during starting
- ii. Field flux is maintained at the maximum value

- iii. Acceleration time is controlled
- iv. Field failure is prevented
- v. Starting torque is always more than the load torque

Of these statements

i, ii, iii and v are correct

78. The following lists relate to speed control of DC motors. Match List I and List II, and select the correct answer using the codes given below the lists:

List I	List II
A. Armature voltage control	1. Speeds above base speed
B. Field current control	2. Speeds below base speed
C. Use of diverter resistance	3. Poor motor efficiency
D. Rheostatic control	4. Speed control of series motor

Codes:

2 1 4 3

79. The DC shunt motor should not be stopped by forcing the starter handle back to the OFF position by hand to avoid

Dangerous sparking at the last stud as handle travels to OFF position

80. The following lists relate to the testing of DC motors. Match List I and List II, and select the correct answer using the codes given below the lists:

List I	List II
A. Voltage-drop test	1. Efficiency
B. Hopkinson's test	2. Separation of iron and friction losses
C. Swinburne's test	3. Open & short-circuited
D. Retardation test	

armature coils

4. Temperature rise

Codes:

3 4 1 2

81. If the frequency of input voltage of a transformer is increased keeping the magnitude of the voltage unchanged, then

hysteresis loss will decrease but eddy current loss remains unchanged

82. Consider the following statements:

1. Audio-frequency transformers are used for providing a path for DC through primary while isolating it from the secondary.
2. The frequency response of power and distribution transformers is not considered.
3. Core-made of soft-ferrite are used in pulse transformers
4. Pulse- transformers are used in radar systems

From the above, the correct answer is

1, 2, 3, 4

83. In a transformer, exciting current is made up of two components; namely magnetizing current I_m and core-loss current I_c . With negligible leakage impedance drop,

I_m lags V_1 by 90° whereas I_c is in phase with V_1

84. A 2200/250 V transformer takes 0.5 A at a power factor of 0.3 on open-circuit. The magnetizing and working components of the no-load primary current are

0.476 A and 0.15 A

85. A 2kVA transformer has an iron loss of 150 W and full-load copper loss of 250 W. The maximum efficiency of the transformer would when the total loss is

300 W

86. Consider a 20 KVA, 2200/220 V, 50 Hz transformer. The O.C. and S.C. test results are as follows:

O.C. test: 220 V, 4.2 A, 148 W (L.V. side)

S.C. test: 86 V, 10.5 A, 360 W (H.V. side)

The voltage regulation at 0.8 p.f. lagging and at full load is:

2.9%

87. The necessary conditions for parallel operation of two single-phase transformers is that these should have the same

1. Polarity
2. kVA rating
3. Voltage regulation
4. Efficiencies
5. Voltage ratio
6. X/R ratio

From these, the correct answer is

1, 3, 5, 6

88. Two 1-phase transformers with equal turns ratio have impedances of $(0.5+j 3) \Omega$ and $(0.6+j 10) \Omega$ with respect to the secondary. If they are operate in parallel, how will they share a load of 100 kW at 0.8 p.f. lagging?

78.2 kW, 21.8 kW

89. A 3-phase star-delta transformer has secondary to primary turns ratio per phase of 5. For a primary voltage of 400 V, the secondary voltage would be

1154.7 V

90. For supplying a balanced 3-phase load of 40 kVA, rating of each transformer in V-V bank should be nearly _____ kVA?

23

91. The following lists relate to the characteristics and applications of 1-phase induction motors. Match List I and List II, and select the correct answer using the codes given below the lists:

List I	List II
A. High starting torque	1. Repulsion-start induction motor
B. High power factor	2. Capacitor-run induction motor
C. Recording instruments	3. Reluctance motor
D. Variable speed	4. A.C. Series motor

Codes:

A	B	C	D
1	2	3	4

92. The effect of increasing the air-gap length between the rotor and stator of a 3-phase induction motor is to

1. Reduce the pulsation loss
2. Reduce the air-gap flux
3. Reduce the torque
4. Worsen the power factor
5. Improve the power factor
6. Increase the efficiency

From these, the correct statements are

1, 3, 4

93. The rotor of an induction motor cannot run at synchronous speed, because if it did so then

1. Rotor E.M.F. would be zero
2. Rotor current would be zero
3. Rotor torque would be zero
4. Rotor power factor would be unity
5. Rotor core loss would be zero
6. Stator core loss would be zero

From these, the correct statements are

1, 2, 3, 4, 5

94. A 3-phase, 4-pole, 50 Hz induction motor runs at a speed of 1440 rpm

1. Its slip is 0.04
2. Its rotor field rotates at 60 rpm with respect to the rotor
3. Its rotor field rotates at 60 rpm with respect to the stator field
4. Its rotor runs at a speed of 60 rpm with respect to the stator field
5. Its rotor field rotates at a speed of 1500 rpm with respect to the stator

From these, the correct statements are

1, 2, 4, 5

95. A 3-phase, 6 pole induction motor is run with a rated voltage V and rated frequency of 50 Hz. The maximum torque obtained is T_{m1} . If the motor is supplied with same voltage but a frequency of 60 Hz, the maximum torque would be approximately

$0.7T_{m1}$

96. A 3-phase induction motor takes a line current of 30 A when started by direct switching. If a star-delta starter is used, the line current would be

10 A

97. An induction motor has a starting torque of 320 N-m when started by direct switching. If starting is through an auto-transformer with 50% tapping, the starting torque will be

80 N-m

98. A 3-phase SCIM running at slip S with synchronous speed N_s clockwise and rotor speed N_r . If its two supply leads are interchanged, then at that instant

1. Slip is $(2-S)$
2. Speed of air-gap field with respect to stator is (N_s+N_r) clockwise
3. Speed of air-gap field with respect to rotor is (N_s+N_r) anti-clockwise
4. Speed of air-gap field with respect to stator is N_s anti-clockwise
5. Effective rotor resistance increases
6. Stator current decreases

From these, the correct answer is

1, 3, 4, 5

99. A 3-phase squirrel cage induction motor draws 10 kW from mains when loaded at a slip of 0.05. The stator losses and mechanical losses are 1 kW and 550 W respectively. Its efficiency is

80%

100. A 3-phase, 50 Hz, induction motor takes a power input of 30 kW at its full-load speed of 1440 rpm. Total stator losses are 1 kW. The slip and rotor ohmic losses at full load are

0.04, 1160 W

101. When speed of an alternator is changed from 3600 r.p.m to 1800 r.p.m, the generated EMF per phases will become

One-half

102. Read the following statements about a cylindrical-rotor alternator.

- i. Emf generated by armature reaction mmf lags armature current by 90°
- ii. Armature reaction due to intermediate lagging power factor is partly cross-magnetizing and partly magnetizing
- iii. Air-gap voltage leads terminal voltage
- iv. Air-gap voltage lags the field flux by 90°
- v. Armature reaction mmf lags the field flux by $(90^\circ + \text{internal power factor angle})$

From these, the correct answer is

1, 3, 5

103. The full-load voltage regulation of an alternator is 6% at 0.8 p.f lagging and at rated speed of 1200 rpm. Its full-load regulation at 0.8 p.f lagging and at 1100 rpm would be, neglect armature resistance

6%

104. An alternator of 300 kW is driven by a prime-mover of speed regulation 4% and another alternator of 400 kW by a prime mover of speed regulation 5%. Governor settings of prime movers are such that their no-load speed is the same. The total load the two alternators in parallel can take, without overloading any one of the two is

620 kW

105. For a salient –pole synchronous machine

$$X_q = X_q' > X_q''$$

106. A salient-pole alternator develops a maximum power of 1.5 per unit under steady state conditions. The amplitude of power developed under transient conditions and the corresponding load angle are, respectively

$$3.8 \text{ p.u.}, \delta > 90^\circ$$

107. A 3-phase synchronous motor connected to an infinite bus operates at a leading power factor. For constant load torque, if the excitation is increased

Load angle δ decreases but power factor angle θ increases

108. During the starting of a 3-phase synchronous motor by damper bars, the field winding is usually short circuited so that starting torque is equal to

Induction motor torque plus an additional torque produced by short-circuited field winding

109. A 3-phase synchronous motor, connected to an infinite bus, is operating with normal excitation. With decreases in load,

1. Armature current decreases
2. Pf becomes lagging
3. Pf becomes leading
4. Load angle decreases
5. Reactive power flows from motor to bus
6. Reactive power flows from bus to the motor

3, 4, 5

110. A 3-phase induction motor draws 1000 kVA at a power factor of 0.8 lag. A synchronous condenser is connected in parallel to draw an additional 750 kVA at 0.6 power factor leading. The power factor of the total load supplied by the mains is

Unity

111. For variable heads of near about but less than 30 meters, which type of turbine is used in hydropower stations?

Kaplan turbine

112. In a nuclear reactor, chain reaction is controlled by introducing

Cadmium rods

113. The cost function of a 50 MW generator is given by $F(P_1) = 225 + 53P_1 + 0.02P_1^2$. When 100% loading is applied, the incremental fuel cost will be

Rs 55 per MWh

114. Match the following

List 1

List 2

A. Nuclear plant

1. Base load

B. Diesel plant

2. Standby

C. Gas turbine

3. Base or peak load

D. Hydro

4. Peak load

1 2 4 3

115. A generating station has a connected load of 43MW and a maximum demand of 20 MW. The units generated being 61.5×10^6 per annum. The load factor of the station is

0.351

116. A generating station has a maximum demand of 25 MW, a load factor of 60%, a plant capacity factor of 50% and a plant use factor of 72%. Then what is the reserve capacity of the plant

5 MW

117. Consider the following statements regarding the pumped storage plants:

- i. A pumped storage plant is a peak load plant
- ii. Pumped storage plants can be used for load frequency control

- iii. The starting time of a pumped storage plant is very long
- iv. Reversible turbines and pumps are very suitable for pumped storage plants

Which of the above statements is/are correct?

i, ii, and iv

118. A conductor is composed of seven identical copper strands each having a radius r , the self GMD of the conductor will be

$2.177 r$

119. For a single phase two wire line, the diameter is 1.213 cm and spacing them is 1.25 m at 50 Hz. The loop inductance is

$22.3 \times 10^{-7} \text{ H/m}$

120. What will be the most economical value of diameter of a single core cable to be used on 50 kV, single phase system, when the maximum permissible stress in the di-electric is not exceeding 40 kV/cm?

3.53 cm

121. What is the empirical formula to calculate the number of strands?

$3n(n+1) + 1$

122. Corona effect can be minimized

Large spacing between conductors.

123. A load has a per unit impedance of 0.6 to a base of 20 MVA and 33 kV. The p.u. impedance to a base of 10 MVA and 11 kV is

2.7

124. For a given base voltage and base volt-amp, the per-unit impedance value of an element is X . What will be the per-unit impedance value of this element when the voltage and volt-amp bases are both doubled?

$0.5X$

125. A star-connected 3-phase 11 kV, 25 MVA alternator with its neutral grounded through a 0.033 p.u reactance has positive, negative and zero-sequence reactances of 0.2 p.u, 0.1 p.u

and 0.1 p.u respectively. A single line to ground fault on one of its terminals would result in a fault MVA of

150 MVA

126. The severity of line-to-ground and three-phase faults at the terminals of an unloaded synchronous generator is to be same. If the terminal voltage is 1.0 p.u and $Z_1 = Z_2 = j0.1$ p.u, $Z_0 = j0.05$ p.u for the alternator, then the required inductive reactance for neutral grounding is

0.0166 p.u

127. What is the value of the zero sequence impedance?

$$Z_0 = Z + 3 Z_n$$

128. The Y_{BUS} matrix of a 100-bus interconnected system is 90% sparse. Hence the number of transmission lines in the system must be

900

129. A power system consists of 300 buses out of which 20 buses are generator bus, 25 buses are ones with reactive power support and 15 buses are the ones with fixed shunt capacitors. All the other buses are load buses. It is proposed to perform load flow analysis in the system using Newton-Raphson method. The size of the Newton Raphson Jacobian matrix is

540 × 540

130. An 800 kV transmission line has a maximum power transfer capacity of P. if it is operated at 400 kV with the series reactance unchanged, then maximum power transfer capacity is approximately

P/4

131. A 500 MW, 21 kV, 50 Hz, 3-phase, 2-pole synchronous generator having a rated power factor of 0.9, has a moment of inertia of 27.5×10^3 kg-m². The inertia constant (H) will be

2.44 MJ/MVA

132. A line voltage regulator is to be used in a single phase 200 V, 5 kVA system to keep the voltage constant for voltage variations within $\pm 10\%$. The rating in kVA of the voltage regulator is

0.5

133. It is difficult to interrupt a capacitive circuit because

The restriking voltage can be high

134. A 50 Hz, 17.32 kV generator is connected a power system. The system reactance and capacitance per phase are 10 mH and 0.02 μF respectively. What is the maximum voltage across the contacts of the circuit breaker at an instant when it passes through zero?

28.28 kV

135. Which of the following circuit breakers is generally used in railway electrification?

Air-blast circuit breaker

136. A fault current of 2000 A is passing on the primary side of a 400/5 C.T. on the secondary side of the C.T., an inverse-time over current relay is connected whose plug setting is set at 50%. The plug setting multiplier will be:

10

137. The neutral of 10 MVA, 11 kV alternator is earthed through a resistance of 5 ohms. The earth fault relay is set to operate at 0.75 A. the CT's have a ratio of 1000/5. What percentage of the alternator winding is protected?

88.2%

138. For complete protection of a three-phase line

Two-phase and one earth fault relays are required

139. In a 3-step distance protection, the reach of the three zones of the relay at the beginning of the first line typically extends into

80% of the first line, 50% of the second line and 20% of the third line

140. A surge of 260 kV travelling in a line of natural impedance of 500 ohm arrives at the junction with two lines of natural impedances of 250 ohm and 50 ohm respectively. The voltage transmitted in the branch lines is

40 kV

141. A cable has the following characteristics , $L = 0.201 \mu\text{H/m}$ and $C = 196.2 \text{ pF/m}$. the velocity of the wave propagation through the cable is

159.24 m/ μs

142. An extra high voltage transmission line of length 300 km can be approximated by a lossless line having propagation constant $\beta = 0.00127$ radians per km. then the percentage ratio of line length to wavelength will be given by

6.06%

143. An example of a motor having short-time duty is found in

Crane drives

144. An electric train employing a dc series motor is running at a fixed speed, when a sudden slight drop in the mains voltage occurs. This would result in

Drop in speed and rise in current

145. For regenerative braking, the regenerated power should have

The same frequency as that of the main supply

146. A locomotive with a mass of 50,000 kg on a track whose coefficient of adhesion is 20 percent will produce a tractive effort of

100 kN

147. A Lamp gives 1500 C.P. in every direction below the horizontal and no illumination above the horizontal, then how much of the total radiation sent vertically downward by the lamp in lumens.

4710

148. Match the following

Column I

(p) Luminous flux

(q) Luminous Intensity

(r) Lumen

(s) Illumination

Column II

(i) Candela

(ii) Candle power x Solid angle

(iii) Lux

(iv) Lumens

p-(iv), q-(i), r-(ii), s-(iii)

149. A 110 V lamp develops 16 C.P. and lamp of the same material and working at the same efficiency develops 25 C.P. on 220 V. Then what is the ratio of diameters of the filaments will be

1.18

150. For dielectric heating, the range of frequency normally employed is

10 MHz to 40 MHz