

Electrical Engineering Question Paper-II

1. The charge entering a certain element is shown in figure. Find the current at $t = 6$ ms

0A

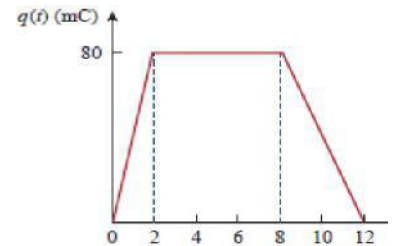

2. Find R_{ab} in the given figure

11 Ω

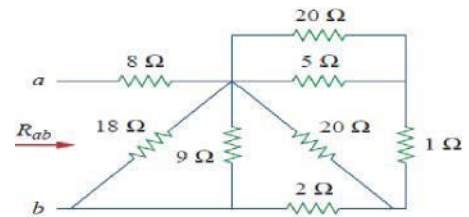

3. Three light bulbs are connected to a 9 V battery as shown in Figure. What is the total current supplied by the battery

5A

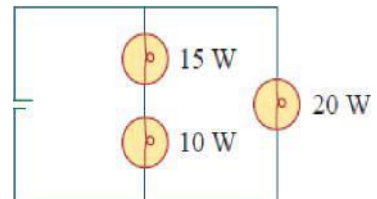

4. An initially uncharged 1-mF capacitor has the current shown in Figure across it. Calculate the voltage across it at $t = 2$ ms

100 mV

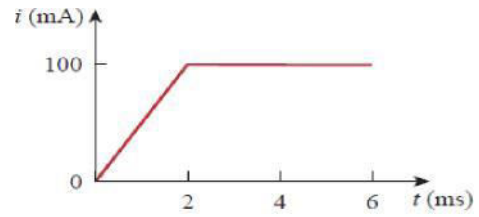

5. When the total charge in a capacitor is doubled, the energy stored:

Is quadrupled

6. Find L_{eq} that may be used to represent the inductive network

- a) $\frac{2}{3} L$
- b) $\frac{6}{7} L$
- c) $\frac{8}{3} L$
- d) $\frac{5}{8} L$

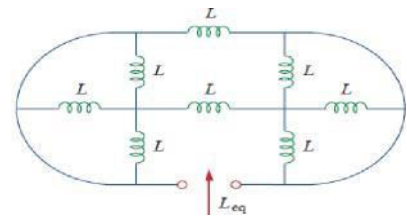

Ans: (d)

7. What are the values of v_0 and i in the given circuit

48 V and -8 A

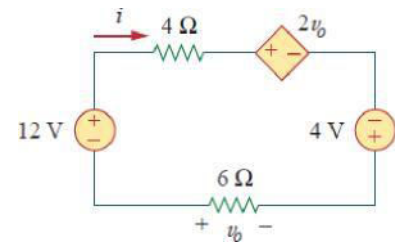

8. Use mesh analysis to find the current in the given circuit

1.5 A

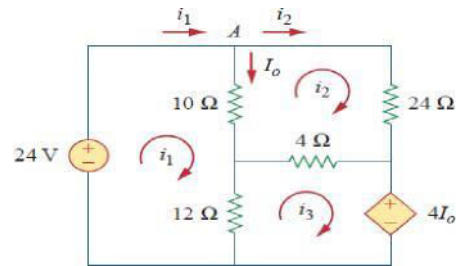

9. Find current i_o in the given circuit

- 0.3

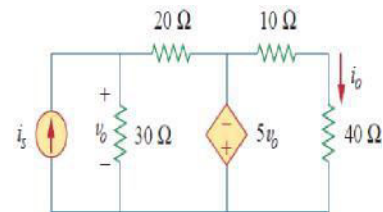

10. A load is connected to a network. At the terminals to which the load is connected, $R_{th} = 10\Omega$ and $V_{th} = 40V$. The

maximum possible power supplied to the load is:

40 W

11. The switch in the figure has been in position A for a long time. At $t = 0$, switch moves to B. find the time constant of the circuit in

2 sec

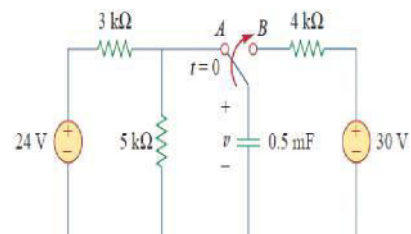

12. The inductor current just before $t = 0$ is

4 A

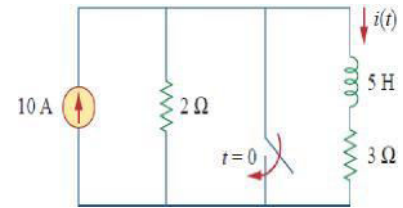

13. Find $v_0(t)$ if $i(0) = 2 A$ and $v(t) = 0$ in the given circuit

a) $-2 e^{-\frac{16}{t}} u(t)$

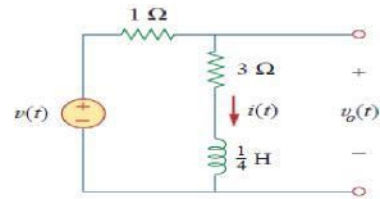

14. Find $i_L(0^-)$ in the given circuit

-6 A

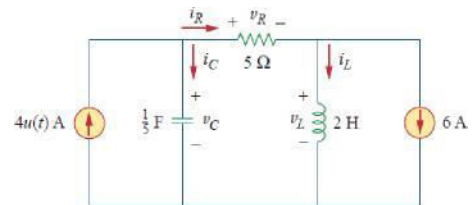

15. If $R = 40 \Omega$, $L = 4 H$ and $C = 1/4 F$. what type of natural response will the series RLC circuit has

Over damped

16. What is the phase angle between $i_1 = -4\sin(377t + 25^\circ)$ and $i_2 = 5\cos(377t - 40^\circ)$

155°

17. A series RC circuit has $V_R = 12$ V and $V_C = 5$ V. The magnitude of supply voltage will be

13 V

18. What value of ω will cause the forced response v_0 in the given figure to be zero?

100 rad/s

19. In the circuit of Fig. , the magnitudes of V_L and V_C are twice that of V_R . The inductance of the coil is

31.8 mH

20. What is the RMS value of the current waveform shown in Fig. if the current passes through the $2\ \Omega$ resistor?

8.165 A

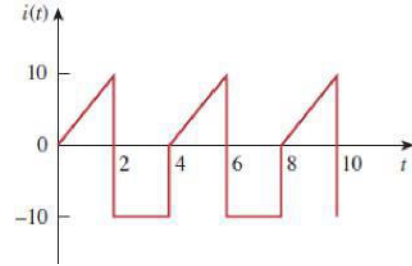

21. If in an **acb** phase sequence, $V_{an} = 100\angle -20^\circ$, then V_{cn} is

$100\angle -140^\circ$

22. A three-phase motor can be regarded as a balanced Y-load. A three phase motor draws 5.6 kW when the line voltage is 220 V and the line current is 18.2 A. what is the power factor of the motor?

0.8075

23. The Rms value of the line voltage is 208 V. what is the average power delivered to load

1.02 kW

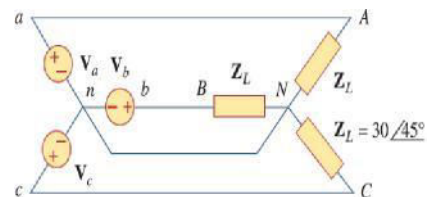

24. A balanced delta-connected load is supplied by a 60-Hz three-phase source with a line voltage of 240 V. Each load phase draws 6 kW at a lagging power factor of 0.8. What is the value of capacitance needed to be connected in parallel with each load phase to minimize the current from the source

207.2 μF

25. Two wattmeter method produces wattmeter readings $P_1 = 1560 \text{ W}$ and $P_2 = 2100 \text{ W}$ when connected to a delta-connected load. If the line voltage is 220 V, what is the per-phase average power?

1220 W

26. The total current $I = I_1 + I_2$ in a circuit is measured as $I_1 = 150 \pm 1 \text{ A}$, $I_2 = 250 \pm 2 \text{ A}$, where the limits of error are given as standard deviations. I is measured as

$(400 \pm 2.24) \text{ A}$

27. The material of wires used for making resistance standards is usually

Manganin

28. If the damping in an d'Arsonval galvanometer is only due to electromagnetic effects, the resistance required for critical damping is

$$\frac{G^2}{2} \sqrt{KJ}$$

29. A moving coil instrument gives a full scale deflection of 10 mA when the potential difference across its terminals is 100 mV. What is the shunt resistance for a full scale deflection corresponding to 100 A

$$0.001 \Omega$$

30. Three moving iron type voltmeters are connected as shown below. Voltmeter readings are V , V_1 and V_2 as indicated. The correct relation among the voltmeter readings is

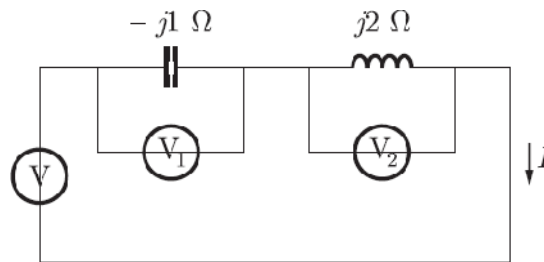

$$V = V_2 - V_1$$

31. A capacitor is connected across a portion of a resistance of the multiplier in order to make the pressure coil circuit non-inductive. The value of this resistance is 'r' while the total resistance and inductance of pressure circuit are respectively R_p and L. Then the capacitance C is

$$L/r^2$$

32. The bridge circuit shown in the figure below is used for the measurement of an unknown element Z_X . The bridge circuit is best suited when Z_X is a

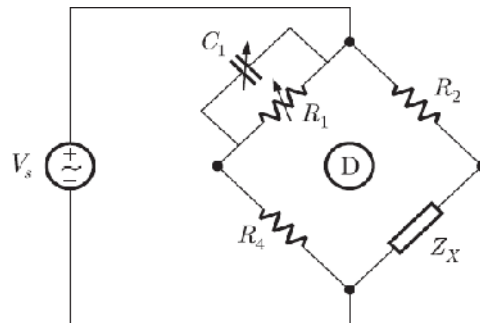

Low Q inductor

33. The equations under balance conditions for a bridge are :

$$R_1 \frac{R_2 R_3}{R_4} \text{ and } L_1 \frac{R_2 R_3}{C_4} \text{ where } R_1 \text{ and } L_1 \text{ are respectively unknown resistance and inductance.}$$

In order to achieve converging balance

R_4 and C_4 should be chosen as variables

34. The power flowing in a 3-phase, 3 wire balanced load system is measured by two wattmeter method. The reading of wattmeter A is 7500 W and of wattmeter B is -1500 W. what is the power factor of the system

$$0.358$$

35. The braking torque provided by a permanent magnet in a single phase energy meter is proportional to the

All of the above

36. Damping which is used in the electrodynamic type wattmeter is

Air friction damping

37. The deflection of an electron beam on a CRT screen is 10 mm. suppose the pre-accelerating anode voltage is halved and the potential between deflecting plates is doubled, the deflection of the electron beam will be

40 mm

38. The bandwidth of a CRO is from 0-20 MHz. The fastest rise time a sine wave can have to be accurately reproduced by the instrument is

17.5 ns

39. Murray loop test is performed on a faulty cable 300 m long. At balance, the resistance connected to the faulty core was set at 15Ω and the resistance of the resistor connected to the sound core was 45Ω . What is the distance of the fault point from the test end in metres

150

40. Loop tests work on the principle of

Wheatstone bridge

41. One Foot-Candle is equivalent to

10.76 lux

42. A 60 W lamp given a luminous flux of 1500 lumen. Its efficiency is

25 lumen/watt

43. The distances of the screen from the lamp under test and standard lamp when adjusted are 1.6 m and 0.9 m respectively. If the standard lamp be of 80 CP, then what is the CP of the lamp under test

252.84 CP

44. The illumination at a surface due to a source of light placed at a distance 'd' from the surface varies as

$\frac{1}{d^2}$

45. The illumination at various points on a horizontal surface illuminated by the same source varies as

Cos³ θ

46. The flux emitted by a lamp in all directions is 1000 lumens. Then what is its MSCP

79.61

47. A lamp of 500 W having a MSCP of 1250 is suspended 2.7 metres above the working plane. Then what is the lamp efficiency

31.42 lumens/watt

48. The illumination at a point on a working plane directly below the lamp is to be 100 lumens/ m². The lamp gives 256 CP, uniformly below the horizontal plane. Then what is the height at which the lamp is suspended in metres

1.6

49. A small assembly shop 16 m long, 10 m wide and 3 m up to trusses is to be illuminated to level of 200 lux. The utilization and maintenance factors are 0.74 and 0.8 respectively. Calculate the number of lamps required to illuminate the whole area if the lumen output of the lamp selected is 3000 lumens

18

50. Carbon arc lamps are commonly used in

Cinema projectors

51. The illumination is directly proportional to the cosine of the angle made by the normal to the illuminated surface with the direction of the incident flux. Above statement is associated with

Lambert's cosine law

52. Which of the following application does not require ultraviolet lamps?

Car lightning

53. The lumens emitted from a 100 W incandescent lamp will not increase if

The diameter of the glass shell is increased

54. Which of the following will need the highest level of illumination?

Proof reading

55. The illumination level required for important traffic routes carrying fast traffic is about

30 lux

56. In a DC machine, which one of the following statements is true?

Lap winding is suitable for higher currents & lower voltages whereas wave winding is suitable for lower currents & higher voltages.

57. The armature of a DC generator has a 2-layer lap-winding housed in 72 slots with six conductors per slot. What is the minimum number of commutator bars required for the armature?

58. A four-pole generator, having wave-wound armature winding has 51 slots, each slot containing 20 conductors. What will be the voltage generated in the machine when driven at 1500 rpm assuming the flux per pole to be 7.0 mWb?

178.5 V

59. A separately excited generator, when running at 1000 rpm supplied 200 A at 125 V. what will be the load current when speed drops to 800 rpm. If I_r is unchanged? Given that the armature resistance is 0.04 ohm and brush drop is 2 V.

159.4 A

60. A DC shunt generator builds up to a voltage of 220 V at no load while running at its rated speed. If the speed of the generator is raised by 25% keeping the circuit conditions unaltered, then the voltage to which the machine would build up will

Increase to 1.25 times 220 V

61. For the voltage build of a self-excited D.C. generator, which of the following is not an essential condition?

Armature speed must be very high

62. A DC shunt generator having a shunt field of 50Ω was generating normally at 1000 rpm. The critical resistance of this machine was 80Ω . Due to some reason, the speed of the prime-mover became such that the generator just failed to generate. The speed at that time must have been

625 rpm

63. A short-shunt cumulatively-compounded DC generator builds up a voltage of 220 V at no load at rated speed. If it is operated as a differentially compounded generator, other things remaining the same, it would build up

220 V

64. A separately-excited DC generator feeds a DC shunt motor. If the load torque on the motor is halved approximately

Armature current of both motor and generator are halved

65. A 4-pole generator has a wave-wound armature with 722 conductors, and it delivers 100 A on full-load. If the brush lead is 8° , then what is the demagnetising ampere turns per pole

802

66. A 400 V, 1000 A, lap-wound DC machine has 10 poles and 860 armature conductors. How many number of conductors are required in the pole face to give full compensation if the pole face covers 70% of pole span

3010

67. The armature of a certain dynamo runs at 800 rpm. The commutator consists of 123 segments and the thickness of each brush is such that the brush spans three segments. What is the time during which the coil of an armature remains short-circuited in milli seconds

1.83

68. A 240 V DC series motor takes 40 A when giving its rated output at 1500 rpm. Its resistance is 0.3 Ω . The value of resistance which must be added to obtain rated torque at 1000 rpm is

1.9 Ω

69. A 240 V DC shunt motor with an armature resistance of 0.5 Ω has a full-load current of 40 A. what is the ratio of stalling torque to the full load torque when a resistance of 1 Ω is connected in series with the armature

4

70. A DC series motor takes 40 A at 220 V and runs at 800 rpm. If the armature and field resistances are 0.2 Ω and 0.1 Ω respectively. Then what is the torque developed in the armature

99.3 N-m

71. A DC motor develops a torque of 200 N-m at 25 rps. At 20 rps it will develop a torque of _____ N-m

200

72. Match List I (DC motor) with List II (characteristics) and select the correct answer using the codes given below the lists:

List I

List II

- | | |
|------------------------------------|--------------------------------------|
| A. Cumulatively compounded motor | 1. Fairly constant speed |
| B. Differentially Compounded motor | 2. It may start in reverse direction |
| C. Series motor | 3. Definite no load speed |
| D. Shunt motor | 4. Never started without load |

Codes:

A	B	C	D
3	2	4	1

73. Consider the following statements :

To control the speed of a DC shunt motor above the base speed over a reasonably wide range, the motor must

1. Have the compensating winding
2. Have interpole winding
3. Be started using 3-point starter
4. Be started using 4-point starter

Of these statements

1, 2 and 4 are correct

74. The series-parallel system of speed control of series motors widely used in traction work gives a speed range about

1 : 4

75. A Dc shunt motor is started at no load and its rated speed is noted as 1000 rpm during winter. After 5 hours of continuous no-load running, its speed would

Become somewhat more than 1000 rpm

76. The lower limit of speed in a Ward-Leonard method of speed control is governed by

1. Losses in both the machines
2. Residual magnetism of the generator
3. Armature circuit resistance of both the machines
4. Speed of the generator-prime mover

From these, the correct answer is

2, 3, 4

77. Consider the following statements regarding the speed control of DC motors:

1. War-Leonard method is suitable for constant-torque drives
2. War-Leonard method is suitable for constant-power drives
3. Field control method facilitates speed control below base speed
4. Armature-resistance control method is more efficient than Ward-Leonard method
5. Field-control method is suitable for constant-torque drives
6. Armature-resistance control method is suitable for constant-torque drives

From these, the correct answer is

1, 2, 6

78. If the field circuit of DC shunt motor, equipped with 3-point starter, gets interrupted accidentally, while running normally, then the

Starter arm will fly back to the off position

79. In Swinburne's method of testing Dc machines, the shunt machine is run as a

Generator at no load at rated speed and rated terminal voltage

80. In Field's test on two series machines

1. Generator field current I_{fg} is more than motor field current I_{fm}
2. $I_{fg} = I_{fm}$
3. Armature voltage of generator V_{tg} is more than armature voltage of motor V_{tm}
4. $V_{tg} < V_{tm}$

From these, the correct statements are

2, 4

81. Two transformers A and B, having identical ratings, are to be designed with flux densities of 1.2 T and 1.4 T respectively.

The weight of transformer A per kVA would be

More than that of transformer B

82. For understanding the behaviour of a transformer, the following laws may be called for

1. Lenz's law
2. Newton's second law
3. Faraday's law of electromagnetic induction
4. Ohm's law
5. Fleming's right-hand rule
6. Right-hand grip rule

From these, the correct answer is

1, 3, 4, 6

83. A 3 : 1 transformer has impedance of $(1 + j 5) \Omega$ on the L.V side and $(9 + j 45) \Omega$ on the H.V side. The total equivalent impedance at the H.V terminals is

18 + j 90 Ω

84. A 50 Hz transformer having equal hysteresis and eddy-current losses at rated excitation is operated at 45 Hz at 90% of rated voltage compared to rated operating point, the core loss under this condition

Reduces by 14.5%

85. A 2200/200 V transformer draws a no-load primary current of 0.6 A and absorbs 400 Watts. Then what are the iron loss and magnetising currents

0.182 A and 0.572 A

86. In a transformer, eddy current loss is 100 watts which is half of the total core loss. If both the thickness of laminations and frequency are increased by 10%, the new core loss would be

256.41 W

87. While performing the open-circuit (O.C.) and short-circuit (S.C.) tests on a transformer to determine its parameters, the status of the low-voltage (L.V.) and high-voltage (H.V.) windings will be such that

In O.C., H.V. is open and in S.C., L.V. is shorted

88. The iron loss in a 100 KVA transformer is 1 kW and full-load copper loss is 2 kW. The maximum efficiency occurs at a load of

70.7 KVA

89. The voltage regulation of a transformer depends on its

1. Equivalent reactance
2. Equivalent resistance
3. Load power factor
4. Transformer size
5. Load current

From these, the correct answer is

1, 2, 3, 5

90. The voltage regulation of a transformer at full-load and 0.8 pf lagging is 2.5%. The voltage regulation at full load 0.8 pf leading will be

- 0.9%

91. Short-circuit test on a single-phase transformer gave the following data:

30 V at 50 Hz, 20 A, pf = 0.2 lag. If s.c. test is performed on 30 V, 25 Hz, then short-circuit current

Increases at a pf > 0.2

92. Consider a 20 KVA, 2200/220 V, 50 Hz transformer. The O.C. and S.C. test results are as follows:

O.C. test: 220 V, 4.2 A, 148 W (L.V. side)

S.C. test: 86 V, 10.5 A, 360 W (H.V. side)

What is the p.f. on short-circuit?

0.4 lag

93. Two 1-phase transformers with equal turns ratio have impedances of $(0.5 + j 3) \Omega$ and $(0.6 + j 10) \Omega$ with respect to the secondary. If they operate in parallel, how will they share a load of 100 kW at 0.8 pf lagging?

78.2 kW, 21.8 kW

94. A single-phase transformer has a rating of 15 kVA, 600 V/120 V. It is reconnected as an autotransformer to supply at 720 V from a 600 V primary source. The maximum load it can supply is

90 kVA

95. A three-phase star-delta transformer has primary to secondary turns ratio per phase of 5. For a primary line current of 10 A, the secondary line current would be

86.6 A

96. If Φ_m is the maximum value of flux due to any one phase, then resultant flux in 2-phase and 3-phase AC machines would respectively be given by

Φ_m and $1.5\Phi_m$; both rotating

97. The stator mmf wave in a 3-phase, 4-pole, 50 Hz IM is found to have fundamental, 5th and 7th harmonic component waves. The rotating fields due to by these harmonics rotate respectively at

1500 rpm, -300 rpm, 214.3 rpm

98. A 4-pole, 50 Hz single phase induction motor has a slip of 5 %. The speed of the motor will be

1425 rpm

99. Torque developed by a three-phase, 400 V, induction motor is 100 N-m. If the applied voltage is reduced to 200 V, the developed torque will be

25 N-m

100. A 3-phase induction motor runs at a slip of 3.2% at normal voltage. For the same load torque, if the supply voltage reduces to 80% of normal voltage, the motor would operate with a slip of

5%

101. A 3-phase, 50 Hz, SCIM develops an electrical torque of 50 N-m at a slip of 0.10. if synchronous speed of IM is 100 rad/s, then electrical damping constant is

5

102. A 3-phase WRIM develops rated torque at a slip of 0.05 with slip-rings short circuited. If the rotor circuit resistance is increased to four times by inserting external resistance in the rotor circuit, then at rated load torque, the slip would be

0.20

103. In a 3-phase IM, if P_g represents the air-gap power, then

Rotor ohmic loss

Mechanical power developed

$s P_g$

$(1 - s) P_g$

104. The rotor impedance of a slip-ring induction motor is $(0.1+j 0.6) \Omega/\text{ph}$. The resistance/ph. to be inserted into rotor to get maximum torque at starting should be

0.5 Ω

105. For a 3-phase, 50 Hz, SCIM, rotor leakage reactance at stand-still is twice of its resistance. The frequency of the supply at which maximum torque is obtained at starting is

25 Hz

106. A 6-pole, 3-phase induction motor develops the maximum torque at 1000 rpm when operated from a 60 Hz supply. Rotor resistance per phase is 1.2Ω . Neglecting stator impedance, the speed at which it will develop maximum torque when operated from 50 Hz supply is

800 rpm

107. A 3-phase pole-changing IM has 72 slots with two independent double-layer windings. One winding has 3 coils/phase/pole and the other has 4 coils/phase/pole. The two respective operating speeds would be in the ratio of

3 : 4

108. From the speed control of a polyphase SCIM, if frequency of operation is decreased with

1. Constant supply voltage V_1 , starting torque $T_{e.st}$ decreases
2. Constant supply voltage V_1 , starting torque $T_{e.st}$ increases

3. $\frac{V}{f_1}$ constant, $T_{e.st}$ decreases

4. $\frac{V}{f_1}$ constant, $T_{e.st}$ increases

From these, the correct answer is

2, 4

109. Match the following :

Type of motor	Characteristic/application
1. 3-phase squirrel-cage IM	A. High starting torque
2. 3-phase slip-ring IM	B. Wide speed control
3. 3-phase double-cage IM	C. Controllable starting torque
4. Static Kramer drive	D. Low-starting torque

Codes:

A	B	C	D
3	4	2	1

110. A 3-phase SCIM takes a line current of 100 A when started by direct switching. If an auto-transformer with 50% tapping is used, the motor-line current and the supply-line current would respectively be

50 A, 25 A

111. Match List I (Parts of a turbo generator used in Thermal power plants) with List II (materials from which these parts are made) and select the correct answer using the codes given below the lists :

List I

- A. Stator core
- B. Rotor core
- C. Stator windings
- D. Slip-rings

List II

- 1. Copper
- 2. Copper alloy
- 3. Silicon steel
- 4. Mild steel
- 5. Aluminium

Codes:

A	B	C	D
3	4	1	2

112. In 48 slot, 4-pole, 3-phase alternator, the coil-span is 10. Its distribution and pitch factors are respectively

0.9577, 0.966

113. The armature of a single-phase alternator is completely wound with T single-turn coils distributed uniformly. The induced voltage in each turn is 2 V (rms). The emf of the whole winding is

1.273 T volts

114. A single-phase, 2000 V alternator has armature resistance and reactance of 0.8Ω and 4.94Ω respectively. The voltage regulation of the alternator at 100 A load at 0.8 leading power factor is

-8.9%

115. Match List I (methods of full-load regulation of 25 MVA alternator at 0.8 P.f lagging) with List II (% regulation) and select the correct answer using the codes given below the lists :

List I

List II

- A. Emf method
- B. Mmf method
- C. Zpf method

- 1. 13%
- 2. 18%
- 3. 32%

Codes:

A	B	C
3	1	2

116. SCR for a synchronous machine is the reciprocal of

- A. X_d in Ω
- B. X_d in p.u
- C. X_s in Ω
- D. X_s in p.u

From above, the correct answer is

B, D

117. X_d , X_d' and X_d'' are steady state d- axis synchronous reactance, transient d- axis reactance and sub-transient d-axis reactance of a synchronous machine respectively. Which of the following statement is true?

$$X_d > X_d' > X_d''$$

118. An alternator of frequency 50.2 Hz is to be synchronized with an infinite bus of frequency 50 Hz by means of three-dark-lamp method. The lamp-flicker per minute will be

12

119. In a synchronous machine connected to an infinite bus, if rotor speed N_r departs from synchronous speed N_s , then

- A. Induction motor (IM) torque is developed if $N_r > N_s$
- B. IM torque is developed if $N_r < N_s$
- C. Induction generator (IG) torque is developed if $N_r > N_s$
- D. IG torque is developed if $N_r < N_s$

From these, the correct answer is

B, C

120. In a synchronous machine, synchronized with infinite bus, the resultant air-gap flux wave (AG) coincides with the field-pole (FP) axis at no load. As a generator, sudden increment in the shaft power input would cause

AG axis to fall behind the FP axis

121. Two identical alternators are running in parallel and carry equal loads. If excitation of one alternator is increased without changing its steam supply, then

It will keep supplying almost the same load

122. Two Alternators A and B running in parallel supply power to a resistive load. For the same terminal voltage and steam inputs, if excitation of alternator A is increased, then

- i. A delivers reactive power at a leading pf
- ii. A delivers reactive power at a lagging pf
- iii. B absorbs reactive power at a leading pf
- iv. B absorbs reactive power at a lagging pf

From these, the correct answer is

ii, iii

123. Two alternators, with excitation voltages E_{f1} and E_{f2} are in parallel at no-load. If E_{f1} is increased with no change in prime mover input, then

- A. Circulating current I_c is set up which magnetizes alternator 1
- B. I_c is setup which de-magnetizes alternator 1
- C. I_c is setup which magnetizes alternator 2
- D. I_c is setup but it produces no magnetizing effect

From these, the correct answer is

B, C

124. A salient-pole alternator has $X_d \simeq 1.2, X_q \simeq 1.0$ and $r_a \simeq 0$. If this alternator delivers rated kVA at unity power factor and at rated voltage, its load angle is

45°

125. A salient-pole alternator develops a maximum power of 1.5 p.u under steady state conditions. The amplitude of power developed under transient conditions and the corresponding load angle are

$3.8, \delta > 90^\circ$

126. A cylindrical-rotor synchronous motor, connected to an infinite bus, is working with a load angle of 30° . If load on the synchronous motor is doubled, excitation remaining constant, then load angle would be

90°

127. A cylindrical-rotor synchronous motor, with negligible armature resistance, operates at

- 1) Unity p.f. if $E_f \cos \phi = V_t$
- 2) Lagging p.f. if $E_f \cos \phi < V_t$
- 3) Lagging p.f. if $E_f \cos \phi > V_t$
- 4) Zero p.f. leading if $E_f > V_t$
- 5) Zero p.f. lagging if $E_f > V_t$

From these, the correct answer is

1, 3, 4

128. A synchronous motor, fed from infinite bus, is delivering half full-load. If an increase in field current causes an increase in the armature current, then the motor will

Deliver reactive power to the bus and absorb active power from the bus

129. A 3-phase synchronous motor is operating at a load angle of 20° and with excitation voltage equal to applied voltage.

The synchronous reactance drop in terms of excitation voltage will be

34.73%

130. Under the conditions of maximum load on a cylindrical-rotor synchronous motor, the reactive power input to the motor is

$$\frac{3V_t^2}{X_s}$$

131. In a synchronous motor running with fixed excitation, when the load is increased three times, its torque angle becomes approximately

Thrice

132. A synchronous motor operating at rated voltage draws 1.0 pu current at 1.0 power factor. The machine parameters are: synchronous reactance 1.0 pu; armature resistance, negligible. Apart from supplying this rated power, if the motor has to supply an additional leading reactive power of 0.8 pu, then the field current has to be increased by

46%

133. The synchronous motor is not inherently self-starting because

The force required to accelerate the rotor to the synchronous speed in an instant is absent

134. Which the following method is used to start a synchronous motor?

Damper winding in conjunction with star-delta starter

135. A salient-pole synchronous motor runs under steady-state conditions at no load with armature current i_a . If the field circuit gets open-circuited, then

it continues to run at the same speed and i_a increases

136. The plot of armature current versus excitation is known as V curves for synchronous generator. Identify the correct combination of load.

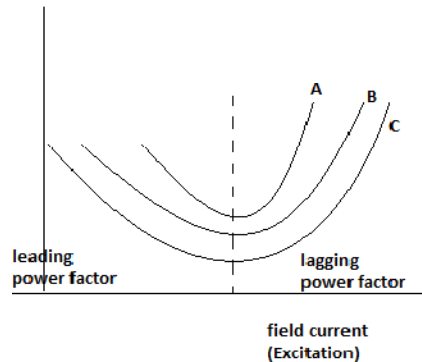

A – full load, B – half load, C – no load

137. A synchronous motor operates at 0.8 p.f lagging. If the field current of the motor is continuously increased :

1. The p.f decreases upto a certain value of field current and thereafter it increases
2. The armature current increases upto a certain value of field current and thereafter it decreases
3. The power factor increases upto a certain value of field current and thereafter it decreases
4. The armature current decreases upto a certain value of field current and thereafter it increases

From these, the correct answer is

3, 4

138. A salient-pole synchronous motor is running with normal excitation. If the excitation is reduced to zero

It becomes a reluctance motor

139. A 3-phase over excited synchronous motor is installed near a 3-phase induction motor (IM) with a view to improve the power factor. With this installation

IM pf and its current does not change, pf of the combination improves

140. An industrial plant has a load of 1500 kVA at an average power factor of 0.6 lagging. Neglecting all losses, the kVA input to a synchronous condenser for an overall power factor of unity will be

1200 kVA

141. A 1-phase, 50 Hz sub-synchronous motor has 2 stator poles and 10 rotor poles. It will run at a speed of

600 rpm

142. In a 1-phase induction motor, according to the double-revolving field theory,
- A. Forward mmf F_f and backward mmf F_b are equal at standstill
 - B. F_f and F_b are equal at all rotor speeds
 - C. Forward flux ϕ_f and backward flux ϕ_b are equal at all rotor speeds
 - D. ϕ_f and ϕ_b are equal at standstill

From above, the correct is

A, B, D

143. A single-phase, 6-pole, 50 Hz induction motor has rotor resistance of 19 ohms and rotor self-reactance of 20 ohms. In addition to zero speed, the motor torque would be zero at a speed of
- 950 rpm**

144. In a 1-phase induction motor, torque developed is proportional to

$$V_1^2$$

145. In various types of split-phase induction motors, the starting torques produced are in the following descending order :
- Capacitor-split, resistor-split, shaded-pole**

146. The starting torque of a capacitor-start induction-run motor is directly related to the angle α between its two winding currents by the relation

c) $\sin \alpha$

147. Split-phase motors are designed to have
- a) Low resistance and high leakage reactance for main winding
 - b) Low resistance and high leakage reactance for auxiliary winding
 - c) High resistance and low leakage reactance for main winding
 - d) High resistance and low leakage reactance for auxiliary winding

From above, the correct is

A, D

148. A 6-pole, 50 Hz, 1-phase induction motor runs at a speed of 9000 rpm. The frequency/frequencies of current in the cage rotor will be
- 5 Hz, 95 Hz**

149. Which one of the following capacitor-start split-phase induction motors will have the largest value of capacitance?

560 W, 1140 rpm

150. Match List I (Types of single-phase motors) with List II (Types of appliances)

List I

1. Permanent magnet type
2. Shaded-pole
3. Universal
4. Capacitor-start, Capacitor-run IM

List II

- A. Rocket
- B. Refrigerator compressor
- C. Sewing machine
- D. Photocopying machine

Codes:

A	B	C	D
<i>1</i>	<i>4</i>	<i>3</i>	<i>2</i>